

The K-Coupler, A New Acoustical-Impedance Transformer

MARTIN C. POPPE, JR., MEMBER, IEEE

Abstract—The validity of a new approach to the problem of matching the acoustical impedance of a piston to the acoustical impedance of the medium into which it radiates power is examined. The device, called a K-coupler, consists in part of a duct or pipe which has an exponentially increasing opening cut in one side. It is shown that the behavior of the K-coupler may be approximately described by the use of equations similar to those that describe the behavior of an exponential horn. Experimental data that show input impedance as a function of frequency are presented.

INTRODUCTION

THIS PAPER examines the validity of a new approach to the problem of matching the acoustic impedance of a piston (e.g., a loudspeaker) to the acoustical impedance of the medium into which it radiates power. The device described is basically a mathematical variation of a standard horn, in which the effect of introducing a slowly varying change in acoustical resistance as a function of length, rather than a change in cross-sectional area, is considered the predominant effect. In the discussion of acoustical horns, the role played by acoustical resistance inside the horn itself is normally ignored because it is usually small and only complicates the mathematical analysis. In the case to be considered here, the resistance that is present is not representative of losses, but rather of useful power that is radiated out of the structure and into the surrounding medium.

HISTORY

Perhaps the most formidable problem encountered in the design of a high-quality acoustical transducer is the sharp decrease in the acoustical radiation resistance that is presented to a piston at low frequencies, i.e., frequencies whose wavelengths are large compared with the dimensions of the piston. It is because of this sharp decrease in radiation resistance that it is difficult to obtain a high level of acoustical energy transfer at low frequencies. There are basically two ways to overcome this naturally imposed restriction.

The first method is to compensate for the decrease in radiation resistance by increasing the velocity of the piston at low frequencies. The standard method that is employed to increase the piston velocity is to make use of the mechanical resonance of the piston. Because the

velocity of a second-order mechanical system near resonance increases at approximately the same rate that the radiation resistance decreases, it is theoretically possible to obtain a uniform output down to the resonant frequency of the piston. This occurs in the mass-controlled range.

The second approach to the problem is to provide the piston with an acoustical structure that will present to the speaker a radiation resistance tailored to its needs and at the same time provide for an efficient release of energy into the air. A common example of such an acoustical structure is a horn.

The acoustical structure introduced in this paper was invented¹ in an attempt to find a better method of impedance matching than that provided by a horn. I have taken the liberty of naming this device the K-coupler. The original reasoning behind this device was along the following lines. If a piston is permitted to radiate into a pipe of infinite length, it would see a constant impedance of value $\rho \cdot c$ (as ρ is the density of the medium, c is the speed of sound in the medium), regardless of the frequency at which it is driven.² If power is to be radiated into the medium, however, the pipe must somehow be terminated at a finite length. If the pipe is simply cut off, we gain very little because the power reflected at the open end causes the input impedance to change as a function of frequency.³ However, if we terminate the pipe in a gradual manner, it may be possible to eliminate the reflection of power from the open end of the pipe. Specifically, if we introduce a small opening in the side of the pipe, and then gradually increase the size of this opening so that there is a uniform release of energy per unit length, and if we terminate the pipe at a point where almost all the energy has been released, then the termination has a negligible effect because only a very small amount of energy is left in the pipe.

A structure that will perform as a K-coupler for the purpose of measuring impedance transforming properties is shown in Fig. 1. The change in cross-sectional areas shown in Fig. 1 is required to simplify the mathematical considerations, and to guarantee that only a negligible amount of energy will be left in the pipe at the point of termination.

¹ J. Karlson, "Acoustic transducer," U. S. Patent 2 816 619, December 17, 1957.

² This assumes that only a plane wave mode is propagating down the pipe, and that the pipe is lossless.

³ This is simply the case of an open end pipe.

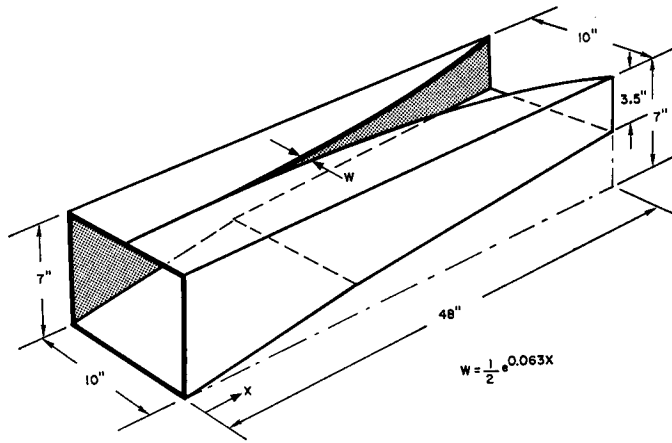

Fig. 1. Experimental model of the K-coupler.

AN APPROXIMATE MATHEMATICAL MODEL

To gain a degree of insight into the expected performance of a K-coupler without going through a great deal of mathematical labor, we will analyze a model in which the wave motion may be described by a one-dimensional wave equation. This requires that only plane waves propagate down the structure, and that the radiation resistance introduced by the tapered opening is assumed to be uniform per unit area and uniformly distributed over the cross section of the structure. The model shown in Fig. 1 approximates these conditions closely in the frequency range of interest.

The wave motion in the one-dimensional model of the K-coupler may be described by the following differential equations:

$$\frac{dV(x)}{dx} = -Y(x, \omega)P(x) \quad (1)$$

$$\frac{dP(x)}{dx} = -Z(x, \omega)V(x) \quad (2)$$

or

$$\frac{d^2P(x)}{dx^2} - \frac{\partial \ln [Z(x, \omega)]}{\partial x} \frac{dP(x)}{dx} - Z(x, \omega)Y(x, \omega)P(x) = 0 \quad (3)$$

$$\frac{d^2V(x)}{dx^2} - \frac{\partial \ln [Y(x, \omega)]}{\partial x} \frac{dV(x)}{dx} - Z(x, \omega)Y(x, \omega)V(x) = 0 \quad (4)$$

$$Z(x, \omega) = R(x) + i\omega L(x)$$

$$Y(x, \omega) = G(x) + i\omega C(x)$$

where

$P(x)$ is the complex amplitude of the pressure at a point x

$V(x)$ is the complex amplitude of the velocity at a point x

$Z(x, \omega)$ is the series impedance of a short section of pipe at point x

$Y(x, \omega)$ is the shunt admittance of a short section of pipe at point x .

In solving these equations, we will assume that $R=0$, and that the power radiated through the tapered opening is represented by a pure shunt conductance G . No attempt will be made to establish the true value of G ; rather, its value will be selected to provide a good indication of its effect on the performance of the K-coupler.

In general, (3) and (4) are nonstationary; but, in the special case where Z and Y vary exponentially as functions of length, it is possible to obtain a solution in closed form. For this reason, the model of the K-coupler that is analyzed in this paper is constructed so that the resulting Z and Y approximate an exponential variation. It should be noted that by assuming Z and Y vary exponentially, we can check our solution to (3) and (4) against the solution for an exponential horn by setting $R=G=0$. For the remainder of this paper, we shall only consider devices in which Z and Y vary exponentially.

When we assume that Z and Y are exponentially varying functions of x , then (remembering that $R=0$),

$$Y(x, \omega) = Y(0, \omega)e^{-\delta x} = (G_0 + i\omega C_0)e^{-\delta x} \quad (5)$$

$$Z(x, \omega) = Z(0, \omega)e^{+\delta x} = i\omega L_0e^{+\delta x}. \quad (6)$$

Then, several simplifications take place:

$$\frac{-\partial \ln [Y(x, \omega)]}{\partial x} = \frac{\partial \ln [Z(x, \omega)]}{\partial x} = \delta \quad (7)$$

and

$$Z(x, \omega)Y(x, \omega) = Z(0, \omega)Y(0, \omega) = \gamma^2 \quad (8)$$

where δ and γ are not functions of x .

Substituting (7) and (8) into (3) and (4) we find:

$$\frac{d^2V(x)}{dx^2} - \delta \frac{dV(x)}{dx} - \gamma^2V(x) = 0$$

$$\frac{d^2P(x)}{dx^2} - \delta \frac{dP(x)}{dx} - \gamma^2P(x) = 0. \quad (9)$$

By the introduction of (7) and (8) we have reduced (3) and (4) to constant-coefficient, second-order, linear, differential equations.

To solve (9) assume a solution of the following form:

$$V(x) = A \left(\frac{Y(x, \omega)}{Z(x, \omega)} \right)^{1/4} e^{-\Gamma x}$$

$$P(x) = B \left(\frac{Z(x, \omega)}{Y(x, \omega)} \right)^{1/4} e^{-\Gamma x}. \quad (10)$$

To find Γ substitute back into (9)

$$[\Gamma + \delta/2]^2 + \delta[\Gamma + \delta/2] - \gamma^2 = 0$$

and then using the quadratic formula, we find,

$$\Gamma = (\gamma^2 + (\delta/2)^2)^{1/2}. \quad (11)$$

To find $Z_0(x)$, the characteristic impedance of the pipe looking to the right from a point x in the pipe, we form the complex ratio of pressure to volume velocity

$$Z_0(x) = \frac{B}{A} \left(\frac{Z(x, \omega)}{Y(x, \omega)} \right)^{1/2} = \frac{B}{A} \left(\frac{Z(0, \omega)}{Y(0, \omega)} \right)^{1/2} e^{+\delta x}. \quad (12)$$

To find an expression for the ratio B/A we solve (1) subject to (10):

$$B[\Gamma + \delta/2] = Z(x, \omega) A \left(\frac{Y(x, \omega)}{Z(x, \omega)} \right)^{1/2}$$

or

$$\frac{B}{A} = \frac{\gamma}{\Gamma - \delta/2} = \frac{\Gamma + \delta/2}{\gamma}. \quad (13)$$

The second form of B/A is obtained by using (11). $Z_0(x)$ may now be written as

$$Z_0(x) = \frac{\Gamma + \delta/2}{\gamma} \left(\frac{Z(0, \omega)}{Y(0, \omega)} \right)^{1/2} e^{+\delta x}. \quad (14)$$

Because of the relation between A and B , we may write the solution as:

$$V(x) = A \left(\frac{Y(x, \omega)}{Z(x, \omega)} \right)^{1/4} e^{-\Gamma x}$$

$$P(x) = A \left(\frac{\gamma}{\Gamma + \delta/2} \right) \left(\frac{Z(x, \omega)}{Y(x, \omega)} \right)^{1/4} e^{-\Gamma x}. \quad (15)$$

DISCUSSION OF Γ AND Z_0

The first aspect of the solutions to (9) that we will consider is how the factor Γ in the exponential differs from γ , the value it would have in uniform pipe. If the case of a lossless structure ($G=0$) such as an infinite exponential horn with a flare constant δ is considered, γ is always a pure imaginary number, and therefore γ^2 is always negative and real.

$$\gamma_{\text{lossless}} = ((i\omega L_0)(i\omega C_0))^{1/2}$$

and

$$\gamma_{\text{lossless}}^2 = -\omega^2 L_0 C_0.$$

Γ may now be written as

$$\Gamma = ((\delta/2)^2 - \omega^2 L_0 C_0)^{1/2}$$

where $(\delta/2)^2$ is always real and positive.

At high frequencies where $-\gamma^2 \gg (\delta/2)^2$, Γ is a pure imaginary number, $\Gamma \approx \gamma$, and power is propagated down the structure without loss.

When $-\gamma^2 \ll (\delta/2)^2$, Γ is a pure real number and $\Gamma \approx (\delta/2)$. In this case, there is no wave propagation down the structure and the character of the solution is one of fast decaying velocity and pressure. Because the structure is lossless there can be no attenuation, and hence no loss; therefore, there must be total reflection.

When $-\gamma^2 = (\delta/2)^2$, it is convenient to define a cutoff frequency ω_{co} as

$$\omega_{co} = \frac{\delta}{2(L_0 C_0)^{1/2}} = \frac{\delta c}{2}.$$

This is the lowest frequency at which real power will be propagated down the structure when it is lossless. That is, ω_{co} is a critical frequency below which no real power will propagate.

In the case of the K-coupler where Y contains a lossy element (i.e., $G \neq 0$), Γ will never be a pure real number, i.e., there will always be real power propagated down the structure regardless of the frequency at which it is driven. However, the amount of power propagated down the line will decrease sharply as the frequency is decreased below ω_{co} . In this case, the real and imaginary parts of Γ may formally be written as

$$\text{Re}[\Gamma] = |\Gamma| \cos \theta$$

$$\text{Im}[\Gamma] = |\Gamma| \sin \theta$$

where

$$|\Gamma| = \{[(\delta/2)^2 - \omega^2 L_0 C_0]^2 + (\omega L_0 G_0)^2\}^{1/4}$$

and

$$\theta = 1/2 \tan^{-1} \frac{\omega L_0 G_0}{(\delta/2)^2 - \omega^2 L_0 C_0}.$$

Figure 2 shows the real and imaginary parts of $\Gamma/(\delta/2)$ plotted as a function of frequency with G_0 as a parameter. From Fig. 1 it is clear that at high frequencies Γ is almost purely imaginary and does not have a significant real part until $\omega = \omega_{co}$. When ω is decreased below ω_{co} the real part of Γ increases rapidly. These results imply that at high frequencies a wave will propagate down the structure with little attenuation per wavelength, but as the frequency is decreased below ω_{co} the rate of attenuation per wavelength rises rapidly.

The plot of $Z_0(0)$ as a function of frequency with G_0 as a parameter is shown in Figs. 3 and 4.

Figures 3 and 4 show that at high frequencies the input impedance of the structure is identical to that of a uniform pipe. As the frequency is lowered below cutoff, the real part decreases in magnitude and the imaginary part either grows or shrinks to zero, depending on the sign of δ .

EXPERIMENTAL VERIFICATION

The ability of the K-coupler to perform as an impedance-matching device was experimentally verified by a measurement of its acoustical input impedance as a function of frequency.

The input impedance was measured using an acoustical "slotted line." The measured resistive and reactive parts of the input impedance are shown in Fig. 5.

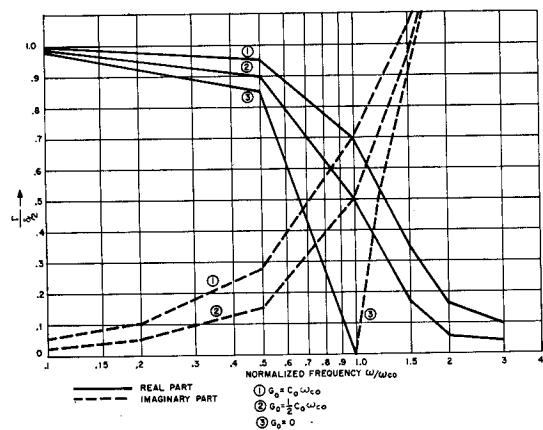

Fig. 2. Real and imaginary parts of $\Gamma/(\delta/2)$ vs. ω/ω_{co} .

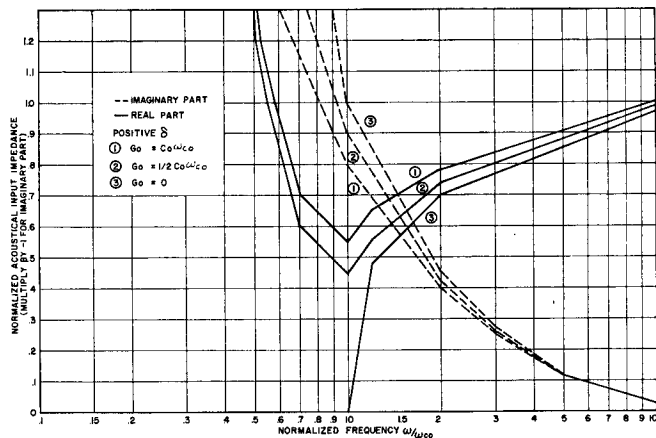

Fig. 3. Normalized acoustical input impedance vs. frequency for positive δ .

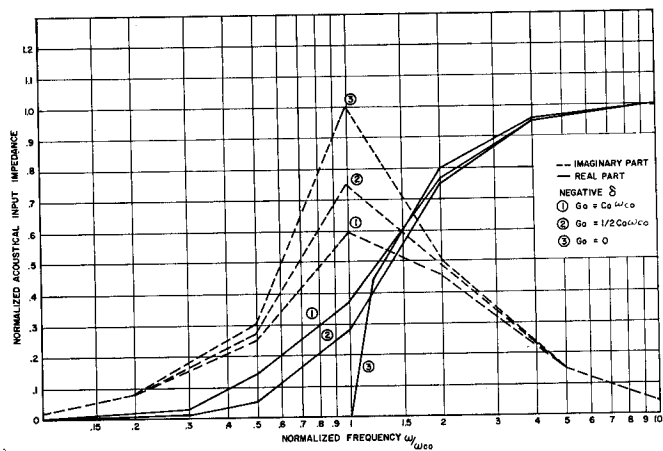

Fig. 4. Normalized acoustical input impedance vs. frequency for negative δ .

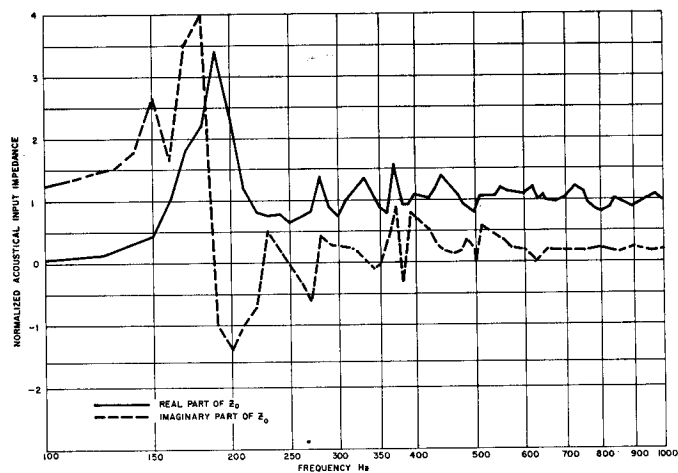

Fig. 5. Measured normalized acoustical input impedance for K-coupler shown in Fig. 1.

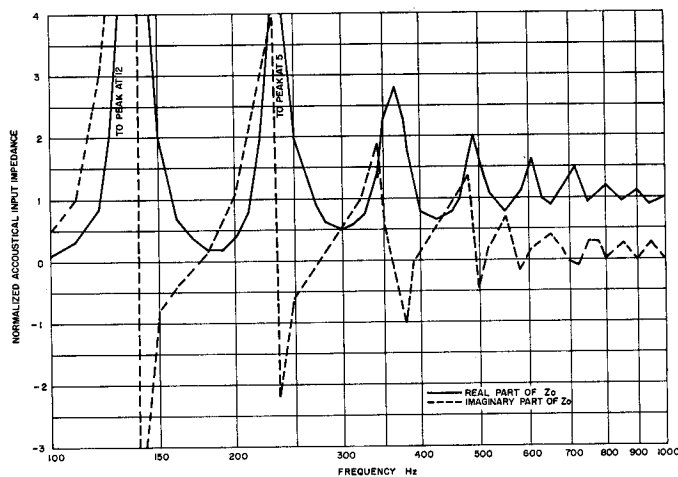

Fig. 6. Calculated normalized input impedance for an exponential horn of comparable dimensions.

With the exception of the resonance peak at 170 Hz, the real part of the impedance curve is a close approximation to the performance predicted in Fig. 4 for above-cutoff operation. Below cutoff the one-dimensional approximation is not valid. The peak at 170 Hz is believed to be attributable to losses in the measurement system, because this was the resonant frequency of the "slotted line" with the K-coupler connected.

THE K-COUPLER COMPARED WITH A HORN

The value of the K-coupler as an impedance-matching device may be best seen by comparison with an exponential horn of approximately equivalent dimensions. A graph of the input impedance of a horn is shown in Fig. 6. The physical sizes of the two structures are compared below.

	K-coupler	Horn
Length	48 in	49 in
Initial opening	$\frac{1}{2}$ in	1 in
Final opening	10 in	10 in
Cutoff frequency	136 Hz	100 Hz
Flare constant	0.063	0.048

In comparing Figs. 5 and 6 it is seen that the input impedance of the K-coupler is a good deal smoother than that of the horn. This is because the resonance peaks and dips in the horn are due to reflection at the mouth of the horn, a problem that is minimized in the K-coupler by the gradual release of energy from the tapered opening.

Another advantage of the K-coupler over a horn is that it does not have a narrow throat region, a factor that severely limits the performance of a horn at high levels.⁴

⁴ Beranek [2], pp. 272-276.

CONCLUSIONS

Many aspects of the K-coupler have not yet been thoroughly investigated. It should be apparent, however, that the configuration presented herein is only one of many possible configurations. For instance, the designer could tailor the tapered opening to fit specific needs, e.g., parts may be formed with a series of slits, or the width of the opening may be varied in any number of ways.

Thus far, nothing has been mentioned concerning the dispersion characteristics or efficiency of the K-coupler. While these characteristics were not measured on the laboratory model, experience with loudspeaker systems designed using this principle in a somewhat more complicated structure has demonstrated that uniform dispersion over a solid angle of 120° is not unusual even at high frequencies and that efficient loudspeakers provide overall system efficiencies of 20 to 50 percent. Further information on the design of acoustical devices employing the K-coupler will appear in a forthcoming paper.

In the light of the mathematical and experimental analysis of the K-coupler presented in this paper, it appears to constitute a valid impedance-matching device. This statement is supported by the impedance curve presented in Fig. 5.

ACKNOWLEDGMENT

The author wishes to thank J. Karlson for his help in preparing this paper.

REFERENCES

- [1] C. F. Adler, et al. *Electromagnetic Energy Transmission and Radiation*. New York: Wiley, 1960.
- [2] L. L. Beranek, *Acoustics*. New York: McGraw-Hill, 1954.
- [3] P. M. Morse, *Vibrations and Sound*, 2nd. ed. New York: McGraw-Hill, 1948.
- [4] H. F. Olson, *Acoustical Engineering*. New York: Van Nostrand, 1957.
- [5] J. C. Slater, *Microwave Transmission*. New York: Dover, 1942

Reprinted from IEEE TRANSACTIONS
ON AUDIO AND ELECTROACOUSTICS
Volume AU-14, Number 4, December, 1966
pp. 163-167

COPYRIGHT © 1966—THE INSTITUTE OF ELECTRICAL AND ELECTRONICS ENGINEERS, INC.
PRINTED IN THE U.S.A.